



Tidal Flooding Mitigation & Shoreline Protection Project

Dock Approach and Electric/Plumbing Reconnect Checklist

WHEN DO I NEED A PERMIT?

The installation, replacement and/or reconnections of electrical, plumbing, Dock and Dock approach. This work requires a Building Permit for dock and dock approach, electrical permit for reconnection and plumbing permit for water reconnection.

REQUIRED PERMIT APPLICATIONS & DOCUMENTS:

- Submit a completed [Broward County Uniform Permit Application](#) (Building Checked) from a licensed General, Building or Residential contractor or owner/builder; for rebuilding Dock and Dock Approach
- Submit a completed [Broward County Uniform Permit Application](#) (Electrical Checked) from a licensed Electrical contractor or owner/builder; for reconnection of electrical to existing Dock (if applicable)
- Submit a complete [Broward County Uniform Permit Application](#) (Plumbing Checked) from a licensed Plumbing contractor or owner/builder; for reconnection of plumbing water supply to existing Dock (if applicable)
- Submit a Site Plan showing existing dock location and location of Stair/Ramp that will access the Dock from one side of the seawall to the other
- Submit Details and Calculations for the Stair/Ramp (Digitally Signed/Sealed by a Design Professional), as they will need to be secured to prevent uplift from surge/flooding waters and High Velocity Hurricane Zone winds.
- Submit the Attached Silt Fence Detail, and indicate Silt Fence on Site Plan, if erosion and sediment control needed
- Submit the Attached Electrical Plan Template, completed with site specific info (if applicable)
- Submit the Attached Plumbing Plan Template, completed with site specific info (if applicable)
- Submit the Attached NOC (Notice of Commencement) after Recording with Broward Recording Office <https://www.broward.org/RecordsTaxesTreasury/Records/Pages/NoticeofCommencement.aspx>
- Approval from Broward County – Environmental & US Army Corp of Engineers (USACOE) <https://www.broward.org/ePermits/Search/Pages/ePermitDetails.aspx?ep permit=8>

I certify to the best of my knowledge that all applicable documents have been submitted.

Print Name

Email Address

Date

Each project is unique, so additional items may be required depending on the scope of work being performed. 1 | 1

BROWARD COUNTY UNIFORM BUILDING PERMIT APPLICATION

Revised Date: 01-08-2026
Effective Date: 03-09-2026

Select One Trade: Building Electrical Plumbing Mechanical Other _____

Private Provider? YES NO If yes, attach [Form # 61G20-2.005-2002-01](#)

Per F.S. 553.791(2)(a), do you have the written fee owner's authorization to use a private provider? YES NO

Application Number: _____ Application Date: _____

1

Job Address: _____ Unit: _____ City: _____

Tax Folio No.: _____ Flood Zn: _____ BFE: _____ Floor Area: _____ Job Value: _____

Building Use: _____ Construction Type: _____ Occupancy Group: _____

Present Use: _____ Proposed Use: _____

Description of Work: _____

New Addition Repair Alteration Demolition Revision Other: _____

Legal Description: _____ Attachment

2

Property Owner: _____ Phone: _____ Email: _____

Owner's Address: _____ City: _____ State: _____ Zip: _____

3

Contracting Co.: _____ Phone: _____ Email: _____

Company Address: _____ City: _____ State: _____ Zip: _____

Qualifier's Name: _____ Owner-Builder License Number: _____

License Exempted per F.S. 489.117(4)(a)1 Business Tax Receipt Number: _____

4

Architect/Engineer's Name: _____ Phone: _____ Email: _____

Architect/Engineer's Address: _____ City: _____ State: _____ Zip: _____

Bonding Company: _____

Bonding Company's Address: _____ City: _____ State: _____ Zip: _____

Fee Simple Titleholder's Name (If other than the owner) _____

Fee Simple Titleholder's Name (If other than the owner) _____ City: _____ State: _____ Zip: _____

Mortgage Lender's Name: _____

Mortgage Lender's Address: _____ City: _____ State: _____ Zip: _____

BROWARD COUNTY UNIFORM BUILDING PERMIT APPLICATION

Job Address: _____ Unit: _____ City: _____

Application is hereby made to obtain a permit to do the work and installations as indicated. I certify that no work or installation has commenced prior to the issuance of a permit and that all work will be performed to meet the standards of all laws regulating construction in this jurisdiction. I understand that a separate permit must be secured for ELECTRICAL WORK, PLUMBING, SIGNS, WELLS, POOLS, FURNACES, BOILERS, HEATERS, TANKS, and AIR CONDITIONERS, etc.

OWNER'S AFFIDAVIT: I certify that all the foregoing information is accurate and that all work will be done in compliance with all applicable laws regulating construction and zoning.

WARNING TO OWNER: YOUR FAILURE TO RECORD A NOTICE OF COMMENCEMENT MAY RESULT IN YOUR PAYING TWICE FOR IMPROVEMENTS TO YOUR PROPERTY. A NOTICE OF COMMENCEMENT MUST BE RECORDED AND POSTED ON THE JOB SITE BEFORE THE FIRST INSPECTION. IF YOU INTEND TO OBTAIN FINANCING, CONSULT WITH YOUR LENDER OR AN ATTORNEY BEFORE COMMENCING WORK OR RECORDING YOUR NOTICE OF COMMENCEMENT.

Form with two columns for signatures and notary information. Includes fields for Signature of Property Owner or Agent, Signature of Qualifier, State of Florida County, Sworn to (or affirmed) and subscribed before me by means of physical presence or online notarization, date, Notary's Signature, Notary Name, Personally Known, Produced Identification, and Type of Identification Produced.

APPROVED BY: _____ Permit Officer Issue Date: _____ Code in Effect: _____
FOR OFFICE USE ONLY FOR OFFICE USE ONLY FOR OFFICE USE ONLY

A jurisdiction may use a supplemental page to request additional information and cite other conditions. Please inquire.

Note: If any development work as described in FS 380.04 Sec. 2 A-G is to be performed, a development permit must be obtained prior to the issuance of a building permit.



NOTICE OF COMMENCEMENT

The undersigned hereby gives notice that improvement will be made to certain real property, and in accordance with Chapter 713, Florida Statutes, the following information is provided in this Notice of Commencement.

PERMIT NUMBER: _____

1. DESCRIPTION OF PROPERTY (Legal description & street address, if available) **TAX FOLIO NO.** _____

SUBDIVISION _____ **BLOCK** _____ **TRACT** _____ **LOT** _____ **BLDG** _____ **UNIT** _____

2. GENERAL DESCRIPTION OF IMPROVEMENT:

3. OWNER INFORMATION: a. Name _____

b. Address _____ **c. Interest in property** _____

Name and address of fee simple titleholder (if other than Owner) _____

4. CONTRACTOR'S NAME, ADDRESS AND PHONE NUMBER:

5. SURETY'S NAME, ADDRESS AND PHONE NUMBER AND BOND AMOUNT:

6. LENDER'S NAME, ADDRESS AND PHONE NUMBER:

7. Persons within the State of Florida designated by Owner upon whom notices or other documents may be served as provided by Section 713.13(1)(a)7, Florida Statutes: NAME, ADDRESS AND PHONE NUMBER:

8. In addition to himself or herself, Owner designates the following to receive a copy of the Lienor's Notice as provided in Section 713.13(1)(b), Florida Statutes: NAME, ADDRESS AND PHONE NUMBER:

9. Expiration date of notice of commencement (the expiration date will be 1 year after the date of recording unless a different date is specified):

WARNING TO OWNER: ANY PAYMENTS MADE BY THE OWNER AFTER THE EXPIRATION OF THE NOTICE OF COMMENCEMENT ARE CONSIDERED IMPROPER PAYMENTS UNDER CHAPTER 713, PART I, SECTION 713.13, FLORIDA STATUTES, AND CAN RESULT IN YOUR PAYING TWICE FOR IMPROVEMENTS TO YOUR PROPERTY. A NOTICE OF COMMENCEMENT MUST BE RECORDED AND POSTED ON THE JOB SITE OF THE IMPROVEMENT BEFORE THE FIRST INSPECTION. IF YOU INTEND TO OBTAIN FINANCING, CONSULT WITH YOUR LENDER OR AN ATTORNEY BEFORE COMMENCING WORK OR RECORDING YOUR NOTICE OF COMMENCEMENT.

**Signature of Owner or
Owner's Authorized Officer/Director/Partner/Manager**

Print Name and Provide Signatory's Title/Office

State of Florida
County of Broward

The foregoing instrument was acknowledged before me by means of physical presence or sworn to (or affirmed) by online notarization, this _____ day of _____ 20__ by _____, who is personally known _____ or produced the following type of identification: _____

(Name of Signer)

Notary Stamp

(Signature of Notary Public)

Under penalties of perjury, I declare that I have read the foregoing and that the facts stated in it are true to the best of my knowledge and belief (Section 92.525, Florida Statutes).

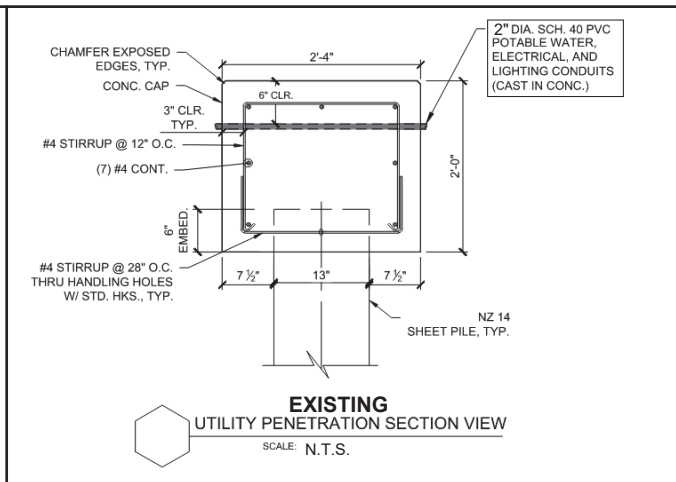
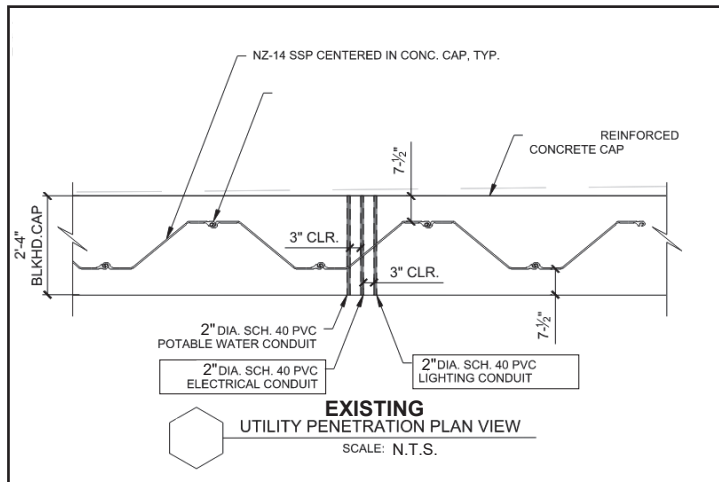

ELECTRICAL NOTES:

- NFPA 70, NEC 2020 - Article 555
- 555.25: Permanent Safety Sign Required that states "WARNING - POTENTIAL SHOCK HAZARD - ELECTRICAL CURRENTS MAY BE PRESENT IN THE WATER"
- 555.3 Ground-Fault Protection: Overcurrent protective devices shall have ground-fault protection
- 555.9 Electrical Connections: Shall be located 12 in. above the deck but not below *electrical datum plane*
- 555.2 Definition: *Electrical Datum Plane*: 2ft above the highest tide level / water level

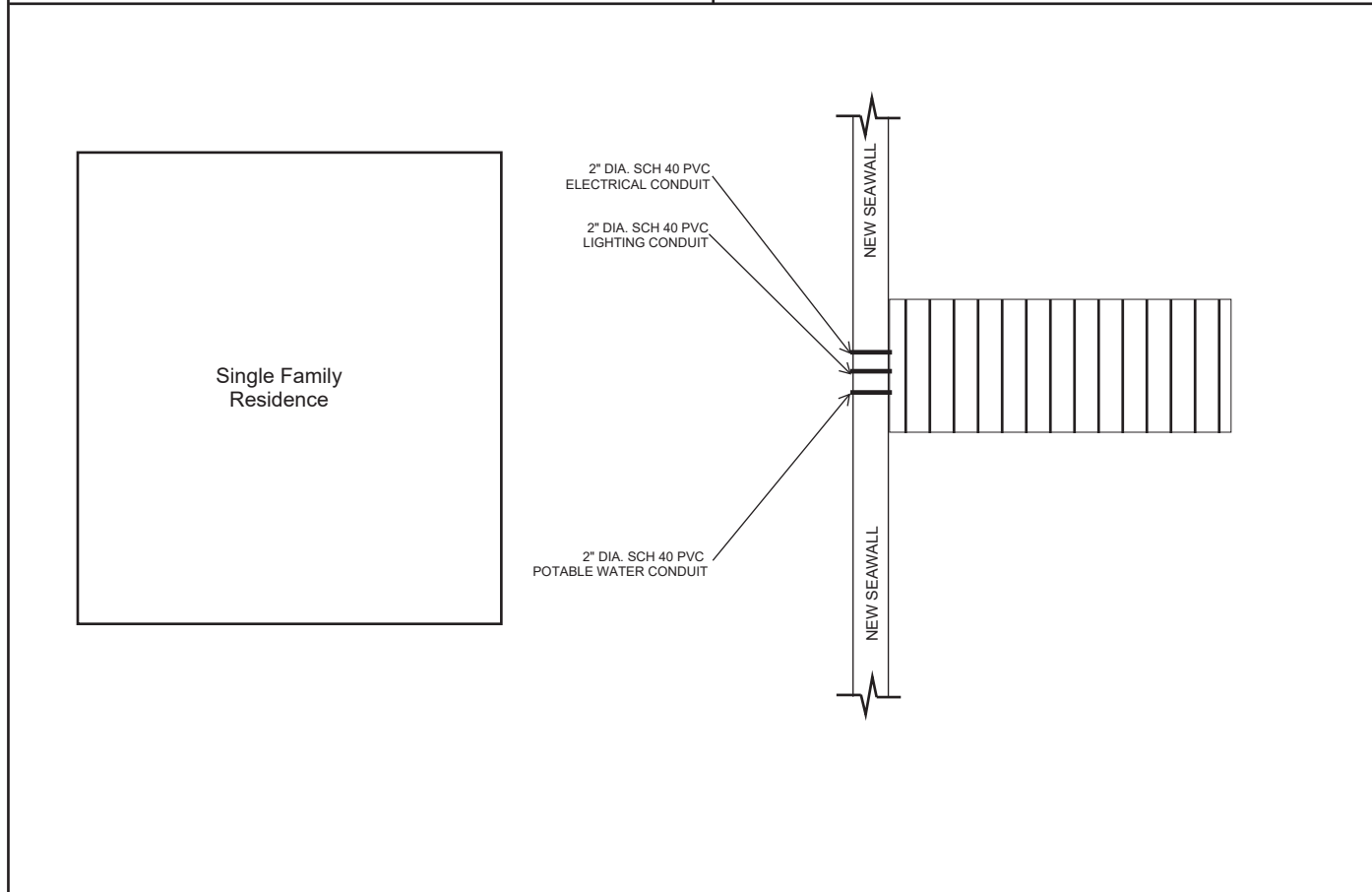

ELECTRICAL INFORMATION & INSTRUCTION:

- PLEASE CHECK WHICH ELEMENTS ARE APPLICABLE:
 - EXISTING LIGHTING
 - EXISTING OUTLETS/RECEPTACLES
 - EXISTING SWITCHES
- PLEASE **ILLUSTRATE** ON DIAGRAM TO LEFT: LOCATIONS OF LIGHTING, OUTLETS & SWITCHES AS WELL AS EXISTING DOCK POWER PEDESTAL (if Applicable)
- PLEASE SPECIFY WIRE (Conductor) SIZES
- PLEASE SPECIFY DEVICE AMPACITY (Amps)
- PLEASE ILLUSTRATE POWER SOURCE/LOCATION
- PLEASE ILLUSTRATE SIZE/LOCATION OF JUNCTION BOXES (if Applicable)

NOTES: _____

Property Owner:

Reconnect Dock Electrical

Contractor:

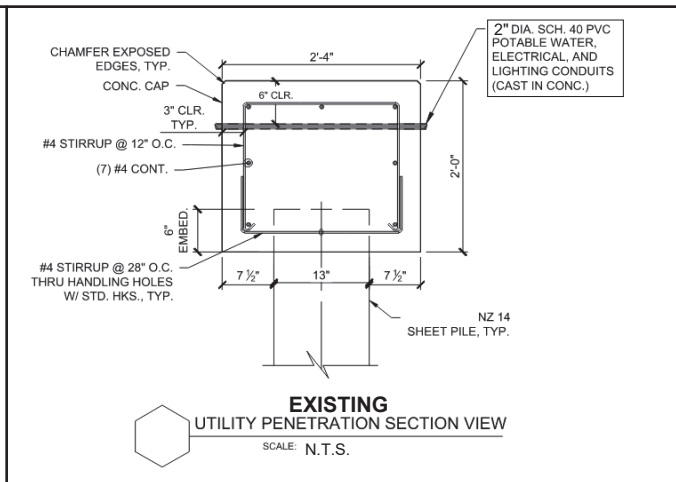
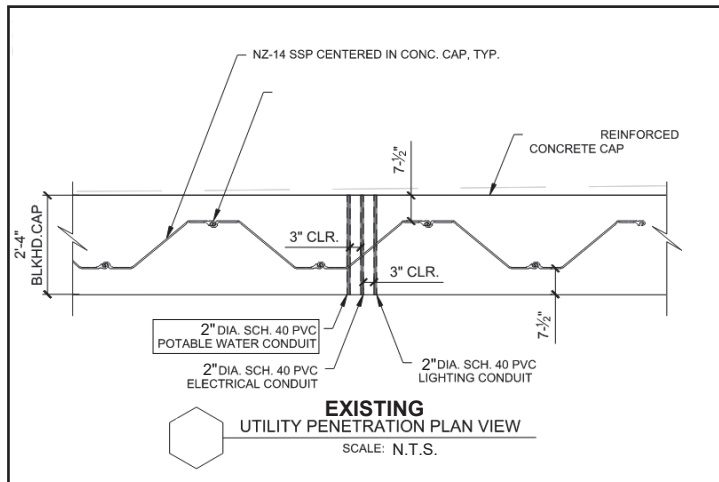

PLUMBING NOTES:

- FBC 2023 8TH EDITION, PLUMBING
- FBC 2023 8TH EDITION, BUILDING
- FBC 2023 8TH EDITION, EXISTING
- 608.16.4.2 Hose Connections
... openings with a hose connection shall be protected by an atmospheric-type or pressure-type vacuum breaker or a permanently attached hose connection vacuum breaker

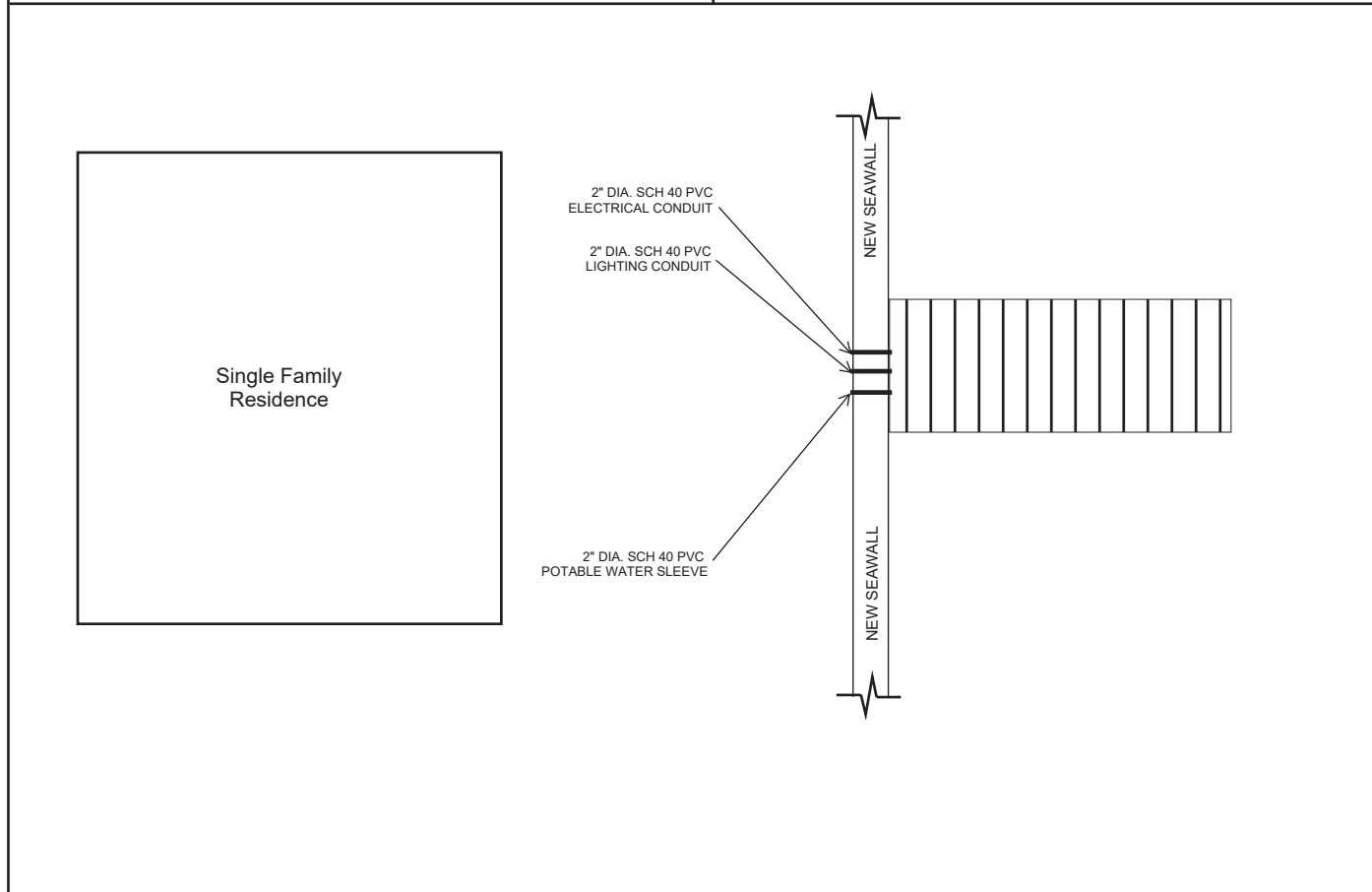

PLUMBING INFORMATION & INSTRUCTION:

- 1.) PLEASE ILLUSTRATE ON DIAGRAM TO LEFT: LOCATIONS OF HOSE BIBBS, PIPING & FIXTURES AS WELL AS EXISTING PEDESTALS (if Applicable)
- 3.) PLEASE SPECIFY PIPE SIZES
- 4.) PLEASE SPECIFY PIPE MATERIAL
- 5.) PLEASE ILLUSTRATE WATER SOURCE

NOTES: _____

Property Owner:

Reconnect Dock Plumbing

Contractor:

SILT FENCE CONSTRUCTION

1. FILTER FABRIC SHALL BE PURCHASED IN A CONTINUOUS ROLL AND CUT TO ALIGNMENT LENGTH TO AVOID JOINTS. WHERE JOINTS ARE UNAVOIDABLE, THE FABRIC SHALL BE SPLICED TOGETHER AT A SUPPORT POST BY TWISTING THE POST OF EACH RUN AROUND EACH OTHER.

2. FILTER FABRIC SHALL BE FASTENED SECURELY TO THE UPSLOPE SIDE OF THE SUPPORT POSTS USING ONE INCH, MINIMUM, LONG HEAVY-DUTY WIRE STAPLES OR TIE WIRES WITH EIGHT INCHES, MINIMUM, OF FABRIC EXTENDED INTO THE TRENCH. DO NOT STAPLE FABRIC TO TREES.

3. COMPACTED SOIL BACKFILL SHALL BE PLACED IN THE 4" BY 6" TRENCH ATOP THE EXTENDED FILTER FABRIC.

4. POSTS SHALL BE CONSTRUCTED OF 2" X 2" X 60" HARDWOOD OR 2" X 4" PINE BY 60" LONG OR COMPARABLE STEEL POSTS.

5. FILTER FABRIC SHALL BE NON-WOVEN "MIRAFI 100X", "EXXON GTF 180" OR EQUAL.

6. APPROVED PREFABRICATED UNITS INCLUDE "GEOFAB", "ENVIROFENCE", OR APPROVED EQUAL.

7. THE MAXIMUM RUN OF SLOPE ABOVE A ROW OF SILT FENCE IS 110 FEET.

THE SILT FENCE MUST BE INSPECTED AFTER EVERY RUNOFF EVENT. ANY DAMAGE MUST BE REPAIRED IMMEDIATELY. SEDIMENT AND OTHER DEBRIS MUST BE REMOVED FROM THE UPSLOPE SIDE OF THE FENCE WHEN IT ACCUMULATES TO THE EXTENT THAT VISIBLE BULGES DEVELOP IN THE SILT FENCE. THE SILT FENCE SHALL BE REMOVED AFTER VEGETATION OR OTHER PERMANENT EROSION CONTROL MEASURES ARE INSTALLED AND FUNCTIONAL.

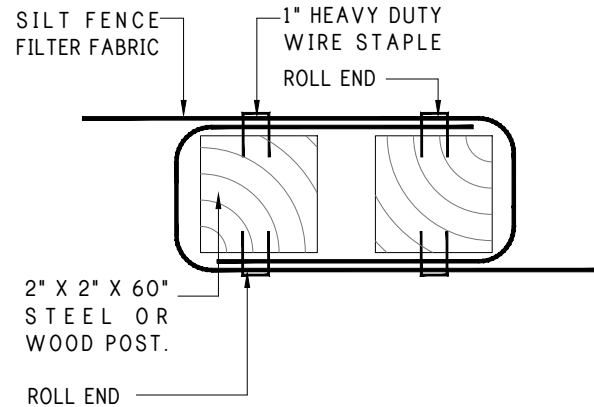

GENERAL SILT FENCE NOTES

INSTALL BEFORE LAND IS DISTURBED

INSTALL ON DOWN SLOPE SIDE OF SITE PARALLEL TO CONTOUR OF THE LAND

STAKE POSTS ON DOWNHILL SIDE

EXTENDED ENDS UP SLOPE ENOUGH TO ALLOW WATER TO POND BEHIND FENCE

TURN ENDS OF FENCE UPHILL

BURY MIN. 6 INCHES OF FABRIC IN TRENCH
LEAVE NO GAPS.

OVERLAP SECTIONS OF SILT FENCE, OR TWIST ENDS OF SILT FENCE TOGETHER.

INSPECT AND REPAIR ONCE A WEEK AND AFTER EVERY RAIN.

REMOVE SEDIMENT IF DEPOSITS REACH HALF THE FENCE HEIGHT

MAINTAIN UNTIL A LAWN IS ESTABLISHED

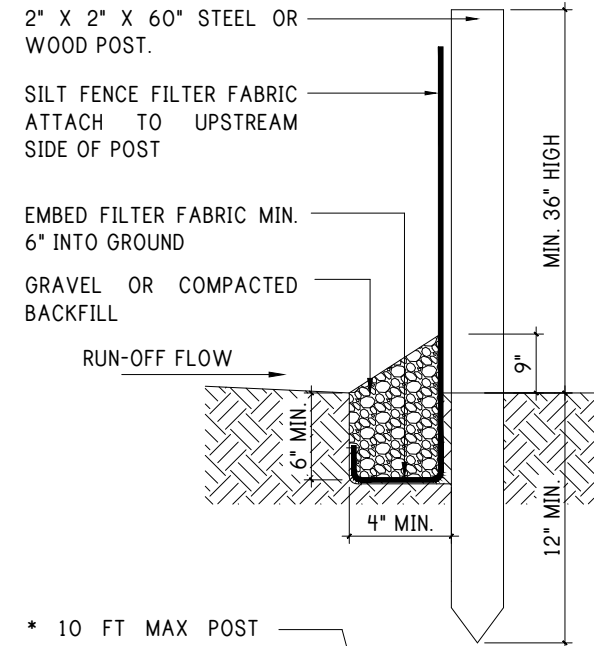

* 10 FT MAX POST SPACING W/ WIRE SUPPORT & 6 FT MAX W/O WIRE SUPPORT

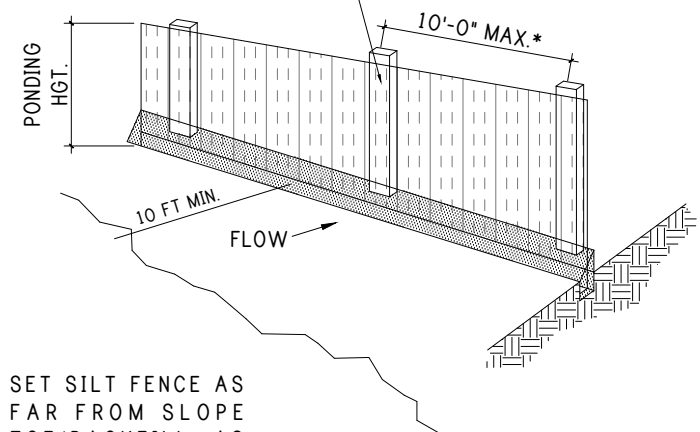

SET SILT FENCE AS FAR FROM SLOPE TOE/BACKFILL AS POSSIBLE, 10 FT., MIN.

RESIDENTIAL SILT/ EROSION FENCE